

# Specification

## CombiMaster® Plus 62 G (6 x 2/1 - 12 x 1/1 GN)

Reference number:



### Description

- Hot-air steamer (combi-steamer mode) conforming to DIN 18866 for most of the cooking methods used in commercial kitchens for the optional use of steam and hot-air, individually, in succession or in combination.

### Working safety

- HACCP data output and software update via integral USB port
- Safety temperature limiter for steam generator and hot-air heating
- VDE approved for unsupervised operation
- Maximum rack height 5 ¼ ft. / 1.60 m when original stand used
- Integral fan impeller brake
- Door handle with right/left and slam function

### Operation

- Mode selector control for cooking modes, separate controls for temperature, core temperature and time settings
- LED illuminated display, visible from a distance
- Clear control panel

### Cleaning, care and operational safety

- Manual cleaning program
- Diagnostic system with automatic service notices displayed
- Menu-guided user descaling program

### Features

- USB Interface
- Probe for core temperature measurement
- Individual programming of 100 cooking programs each with up to 6 steps
- 5 fan air speeds, programmable
- Integral, maintenance-free grease extraction system with no additional grease filter
- Cool-down function for fast cabinet fan cooling
- High-performance fresh steam generator
- Automatic, active rinsing and drainage of steam generator by pump
- Automatic adaptation to the installation location (height, climate, etc.)
- Unit door with rear-ventilated double-glass panel and hinged inner panel
- Seamless hygienic cooking cabinet with rounded corners, cabinet with splash guard - stops water from spilling out
- Removable, swivelling grid shelves (distance between rails 2 5/8" / 68 mm)
- Material inside and out 304 (DIN 1.4301) stainless steel
- Hand shower with automatic retracting system
- Separate solenoid valves for normal and softened water
- Fixed waste water connection conforming to SVGW requirements where permitted
- Splash and hose-proof to IPX 5
- Demand-related energy supply by means of modulating, low-noise high-performance blower burner system
- Lengthwise loading for 18"x26" or 2/1, 1/1 GN accessories
- Temperature unit is selectable in °C or °F
- Height-adjustable feet
- Dynamic air mixing

### ClimaPlus



Climate management - humidity measurement, 5-stage setting and regulation

### Combi-Steamer mode



Steam between 30 °C and 130 °C



Hot-air from 30 °C-300 °C



Combination of steam and hot-air  
30 °C-300 °C

### Approval/Labels



Planner/Designer:



# Specification/Data sheet

Wed Nov 26 05:00:33 CET 2014

## CombiMaster® Plus 62 G (6 x 2/1 - 12 x 1/1 GN)

### Technical Info

<b>Lengthwise loading for:</b>	2/1, 1/1 GN	<b>Water connection (pressure hose):</b>	3/4" / d 1/2"	<b>Rated thermal load natural gas total:</b>	105,000 BTU (28 kW)
<b>Capacity (GN-container/grids):</b>	6 x 2/1 GN / 12 x 1/1 GN	<b>Water pressure (flow pressure):</b>	150-600 kPa / 0,15-0,6 Mpa / 1,5 - 6 bar	<b>Rated thermal load natural gas "Steam":</b>	79,000 BTU (21 kW)
<b>Number of meals per day:</b>	60-160	<b>Water drain:</b>	DN 50 mm	<b>Rated thermal load natural gas "Hot-air":</b>	105,000 BTU (28 kW)
<b>Width:</b>	42 inch / 1.069 mm	<b>Gas supply/connection:</b>	3/4" (NPT)	<b>Connected load electric :</b>	0,77 kW
<b>Depth:</b>	38 1/4 inch / 971 mm	<b>Rated thermal load Liquid gas LPG total:</b>	105,000 BTU (28 kW)	<b>Mains connection</b>	1 NAC 230V 50/60Hz
<b>Height:</b>	30 3/4 inch / 782 mm	<b>Rated thermal load Liquid gas LPG "Hot-air":</b>	79,000 BTU (21 kW)	<b>Breaker Size / (amp draw)</b>	1 x 16 A
<b>Weight (net):</b>	359.5 lbs / 163.5 kg	<b>Liquid gas LPG "Steam":</b>		<b>Cable crossection</b>	3 x 2,5 mm <sup>2</sup>
<b>Weight (gross):</b>	354 lbs / 161 kg			Other voltage on request!	

### Installation

- Attention: Copper wiring only!
- Recommended left hand clearance for service and maintenance 20" / 500 mm. It must be a minimum of 14" / 350 mm if heat sources are affecting the left side of the unit
- Installations must comply with all local electrical, plumbing and ventilation codes

### Options

- Security version/prison version
- Left hinged door
- Sous-Vide core temperature probe
- Interface Ethernet
- Safety door lock
- Externally attached core temperature probe
- Mobile oven rack
- Lockable control panel
- Connection to energy optimising systems "Sicotronic" + Potential free contact for operation indication included
- Special voltages
- Control panel protection

### Accessories

- GN Containers, Trays, Grids
- Stands / Cabinets
- Thermocover
- Transport Trolley
- KitchenManagement System
- Heat shield for left hand side panel
- Superspike (poultry grids), CombiGrill®
- Special Cleaner and Grill Cleaner
- Grease drip container
- Mobile plate rack
- Draft diverter with silencer
- Catering kit

### RATIONAL UK

Unit 4 Titan Court, Laporte Way  
 Portenway Business Park, Luton LU4 8EF  
 Tel.: +44 (0) 1582 480388, Fax.: +44 (0) 1582 485001

Visit us on the internet: [www.rational-online.uk](http://www.rational-online.uk)

We reserve the right to make technical improvements

## CombiMaster® Plus 62 G (6 x 2/1 - 12 x 1/1 GN)

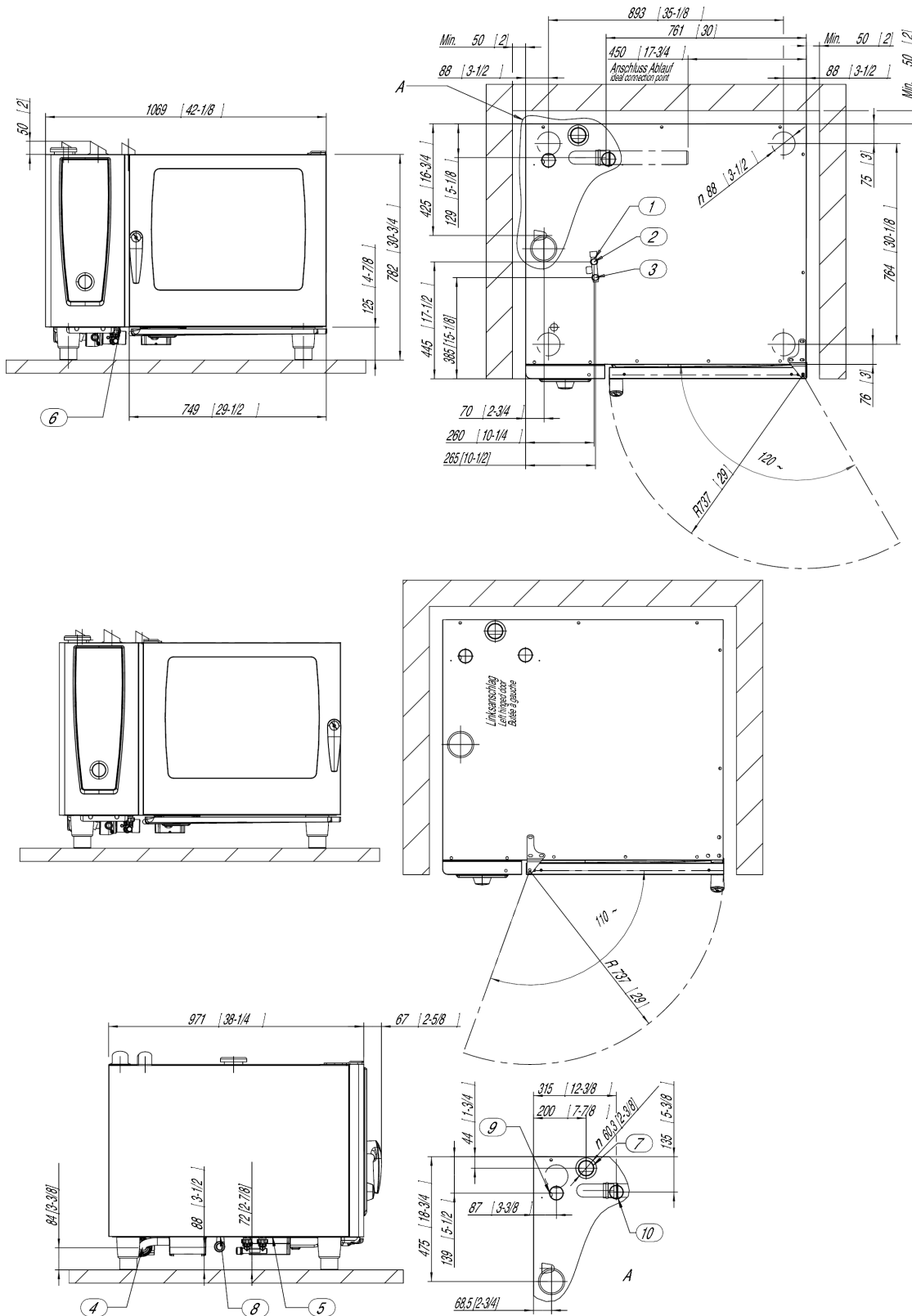

1. Common water supply (cold water) "Single" water connection as shipped 2. Water supply cold water / condensate "Split" water connection 3. Water supply cold / Treated "Split" water connection 4. Water drain 5. Electrical connection wire entrance 6. Chassis Ground connection 7. Steam Vent pipe DN 2 3/8" / 60 mm 8. Gas connection 3/4 NPT 9. Steam burner exhaust pipe 10. Hot-air burner exhaust pipe 11. minimum distance 2" / 50 mm 12. Measurements in mm (inch)